



BAYSIDE

THE YACHTING EXPERIENCES

BAYSIDE-X.COM
INFO@BAYSIDE-X.COM



Roll UP

200/230/250/280/320 KAM/AL

Owner's Manual

Before operating your boat, please read this manual carefully

PLEASE KEEP THIS MANUAL IN A SECURE PLACE, AND HAND IT OVER TO THE NEW OWNER WHEN YOU SELL THE BOAT.

Content

General Introduction	3
Safety Alerts.....	4
Safe Boating Recommendations.....	4
Pre-operation Check List	5
Specifications: Roll Up	6
General Arrangement.....	7
Recommended Seating Arrangement	8
Builder’s Plate:.....	9
Boat Components.....	10
Floorboard Installation	11
Information Connected With the Risk of Flooding and Stability.....	13
Transporting	14
Engine Start	14
Operation.....	15
Man-overboard Prevention and Recovery	19
Maintenance.....	20
Warranty.....	23
Service assistance	25

To ensure that you gain maximum satisfaction from your Highfield boat, please read this Owner's Manual carefully. It contains all the safety and operation instructions that you need to get the most out of your new Highfield.

General Introduction

This manual has been compiled to help you to operate your boat with safety and pleasure. It contains details of the boat; the equipment supplied or fitted; its systems and information on their operation. Please read it carefully, and familiarize yourself with the boat before using it.

This owner's manual is not a course on boating safety or seamanship. If this is your first boat, or if you are changing to a type of boat you are not familiar with, for your own comfort and safety, please ensure that you obtain handling and operating experience before "assuming command" of the boat. Your dealer or national sailing federation or yacht club will be pleased to advise you of local sea schools, or competent instructors.

Ensure that the anticipated wind and sea conditions will correspond to the design category of your boat, and that you and your crew are able to handle the boat in these conditions.

Even when your boat is categorized for them, the sea and wind conditions corresponding to the design categories A, B and C range from severe storm conditions for category A, to strong conditions for the top of category C, open to the hazards of a freak wave or gust. These are therefore dangerous conditions, where only a competent, fit and trained crew using a well maintained boat can satisfactorily operate.

This owner's manual is not a detailed maintenance or trouble-shooting guide. In the case of difficulty, refer to the boat builder or his representative. If a maintenance manual is provided, use it for the boat's maintenance.

Always use trained and competent people for maintenance, fixing or modifications. Modifications that may affect the safety characteristics of the boat shall be assessed, executed and documented by competent people. The boat builder cannot be held responsible for modifications that he has not approved.

In some countries, a driving license or authorization is required, or specific regulations are in force.

Always maintain your boat properly and make allowance for the deterioration that will occur in time and as a result of heavy use or misuse of the boat.

Any boat, no matter how strong it may be, can be severely damaged if not used properly. This is not compatible with safe boating. Always adjust the speed and direction of the boat to sea conditions.

If your boat is fitted with a life raft, carefully read its operating manual. The boat should have onboard the appropriate safety equipment (lifejackets, harness, etc.) according to the type of boat, weather conditions, etc. This equipment is mandatory in some countries. The crew should be familiar with the use of all safety equipment and emergency maneuvering (man overboard recovery, towing, etc.), sailing schools and clubs regularly organize drill sessions.

All persons should wear a suitable buoyancy aid (life jacket/personal floatation device) when on deck. Note that, in some countries, it is a legal requirement to wear a buoyancy aid that complies with their national regulations at all times.

Safety Alerts

This manual uses the following safety alerts to draw your attention to special safety instructions that should be followed.

Degree of hazard and corresponding safety labels:

Danger

Denotes that an extreme intrinsic hazard exists which would result in high probability of death or irreparable injury if proper precautions are not taken.

Warning

Denotes that a hazard exists which can result in injury or death if proper precautions are not taken.

Caution

Denotes a reminder of safety practices or directs attention to unsafe practices which could result in personal injury or damage to the craft or components or to the environment.

Safe Boating Recommendations

1. Always wear a life jacket

Local authorities require that you carry an approved personal flotation device, or life jacket, for each person aboard your vessel. We recommend wearing a life jacket at all times while boating.

2. Use the kill switch lanyard

The operator of the boat must at all times wear a switch lanyard while driving. In the event of accidental ejection or loss of balance, the boat will shut off automatically. Wearing a switch lanyard would possibly saving the driver's life or that of someone else.

3. Know your boat

Knowing your boat is the foundation of good seamanship, which is simply the skill of managing a boat and encompasses; navigation, safety, boat handling, line handling, anchoring, troubleshooting of engine problems and appropriate emergency response.

4. Take a boating safety course and know the navigation rules

A boating course will teach you the basics of seamanship mentioned above. The knowledge you will gain by taking a boating safety course will never be wasted. Learn to read nautical charts, and keep them on your vessel to become familiar with the area in which you boat. Taking a boating safety course is the next step, where you will learn to navigate using charts, GPS, RADAR and a compass.

5. Boat sober

Alcoholic drinks are even more dangerous on the water than on land because the marine environment accelerates impairment. Besides the safety risks, boating while intoxicated, or BUI, is illegal and heavy penalties are enforced by both state and federal agencies.

6. Avoid collisions.

Observe the rules of priority as defined in the Navigation Rules and imposed by the international regulations for preventing collisions at sea. Ensure that you always have sufficient room to stop or manoeuvre if necessary in order to avoid a collision. Avoid abrupt maneuvers at full speed.

7. Protect people

Always slow down and exercise extreme caution any time you are boating in area where there are people in the water.

8. Respect for environment

Please be aware of local environment laws and international regulations against marine pollution and respect them as much as possible.

9. Control Speed

Do not drive at top speed in areas of heavy boat traffic or in situations of reduced visibility, strong winds or heavy seas. Reduce the boat's speed in big waves and wake out of courtesy and for your own safety and the safety of others. Observe speed limits and "NO WASH" signs.

10. Others:

Do not sit in the bow cockpit when the boat is moving at high speed.

Danger

When operating, passengers must avoid standing up or hanging appendage outside of the boat. Leaking fuel is a fire hazard, inspect fuel system regularly. Shut off the engine before boarding from the water.

Warning

Should the operator or passenger fall out of the boat, the possibility of serious injury or death from being run over by the boat can be greatly reduced by stopping the engine immediately. Always properly connect both ends of the stop switch lanyard to the stop switch and the operator.

Caution

Passengers must use suitable PFDs. Special PFDs are designed for children or watersport activities. (Personal Flotation Device)

Pre-operation Check List

- a). Make sure every passenger is wearing a suitable personal flotation device.
- b). Make sure there is an extra buoyant device that can be thrown to rescue person in the water.
- c). If boating with passengers, instruct at least one passenger in the basics of boat handling, starting and operation of the outboard motor.
- d). Check that every passenger is securely seated and hold a safe line, grab handle or rope.
- e). Make sure that there is a 4m towing rope in the boat.
- f). Make sure the load in the boat is distributed evenly.
- g). Make sure you respect the maximum load specified for the boat as described on the manufacturer's plate.
- h). Make sure that all safety gear is on board, e.g. whistle, floating ropes, waterproof flashlight, first aid kit, fresh water, tool kit...
- i). Check that the boat is equipped with 2 paddlers or oars.
- j). Make sure the outboard motor is securely fastened to the transom.
- k). Make sure the drain plug is fully functional.
- l). Check the pressure level in each chamber using a pressure gauge. Recommended working pressure is displayed on manufacturer's plate.
- m). Check fuel tank level and make sure it suits your plan.
- n). Start the outboard motor and make sure it stops when the lanyard is disconnected from the switch.

Specifications: Roll Up



Description		AL Models									
		200AL		230AL		250AL		280AL		320AL	
Length	a	1.99m	6'6"	2.30m	7'7"	2.52m	8'3"	2.80m	9'2"	3.20m	10'6"
Beam	c	1.39m	4'7"	1.39m	4'7"	1.58m	5'2"	1.61m	5'3"	1.61m	5'3"
Inside Length	b	1.28m	4'2"	1.57m	5'2"	1.64m	5'5"	1.94m	6'4"	2.33m	7'8"
Inside Width	d	0.61m	2'	0.61m	2'	0.70m	2'4"	0.71m	2'4"	0.72m	2'4"
Bow Height	e	600mm	24"	610mm	24"	655mm	26"	670mm	26"	700mm	28"
Stern Height	f	358mm	14"	405mm	16"	465mm	18"	440mm	17"	450mm	18"
Weight		28kg	62lbs	31kg	68lbs	37kg	82lbs	42kg	93lbs	48kg	106lbs
Max Passenger		2		2		3		4		4+1	
Max Load		250kg	551lbs	350kg	772lbs	450kg	992lbs	500kg	1102 lbs	565kg	1246 lbs
Max Engine Power		3.5HP	2.61kw	4HP	2.98kw	6HP	4.48kw	10HP	7.46kw	15HP	11.19kw
Shaft		Short									
Tube Material		PVC or Hypalon coated fabrics									
Tube Diameter		360mm	14"	360mm	14"	430mm	17"	430mm	17"	430mm	17"
Airtight Chambers		3		3		3		3		3	
Description		KAM Models									
		200KAM		230KAM		250KAM		280KAM		320KAM	
Length	a	2.00m	6'7"	2.30m	7'7"	2.50m	8'2"	2.80m	9'2"	3.20m	10'6"
Beam	c	1.37m	4'6"	1.37m	4'6"	1.61m	5'3"	1.61m	5'3"	1.61m	5'3"
Inside Length	b	1.28m	4'2"	1.50m	4'11"	1.63m	5'4"	1.94m	6'4"	2.36m	7'9"
Inside Width	d	0.61m	2'	0.61m	2'	0.71m	2'4"	0.71m	2'4"	0.71m	2'4"
Bow Height	e	600mm	24"	610mm	24"	655mm	26"	670mm	26"	700mm	28"
Stern Height	f	358mm	14"	405mm	16"	465mm	18"	465mm	18"	450mm	18"
Weight		24kg	53lbs	26kg	57lbs	30kg	66lbs	33kg	73lbs	36kg	79lbs
Max Passenger		2		2		3		4		4+1	
Max Load		250kg	551lbs	350kg	772lbs	450kg	992lbs	500kg	1102 lbs	565kg	1246 lbs
Max Engine Power		3.5HP	2.61kw	4HP	2.98kw	6HP	4.48kw	10HP	7.46kw	15HP	11.19kw
Shaft		Short									
Tube Material		PVC or Hypalon coated fabrics									
Tube Diameter		360mm	14"	360mm	14"	430mm	17"	430mm	17"	430mm	17"
Airtight Chambers		3		3		3		3		3	

General Arrangement

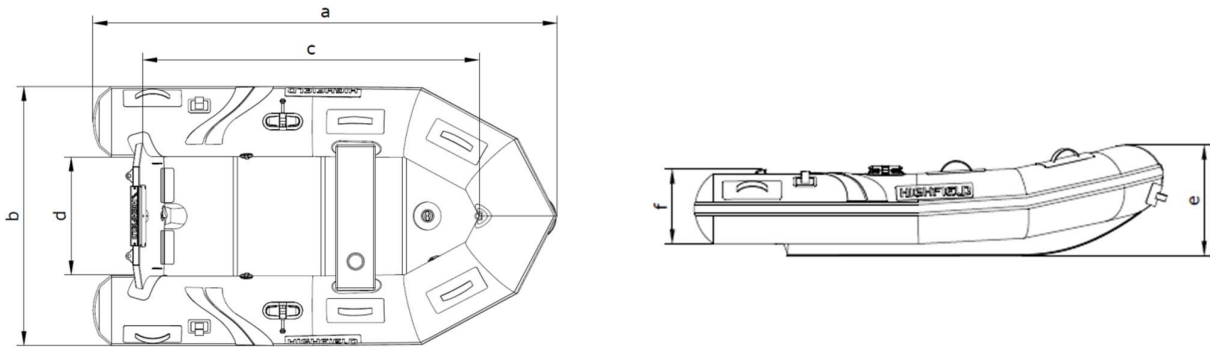

Notes:

- a) Overall Length: Including removable parts that can be dismantled, without affecting the structure of the boat.
- b) Inside Length: Excluding removable parts that can be dismantled, without affecting the structure of the boat.
- c) Beam: Including removable parts that can be dismantled, without affecting the structure of the boat.
- d) Inside width: Excluding removable parts that can be dismantled, without affecting the structure of the boat.
- e) Fuel Tank Capacity: It may not be possible to use this capacity fully depending on the trim and load of the boat. It is recommended to keep a reserve of 20% in the fuel tanks.
- f) Category C: Craft designed to operate in winds up to Beaufort force 6 and the associated wave heights (significant wave height up to 2m). Such conditions may be encountered in exposed inland waters, in estuaries, and in coastal waters in moderate weather conditions.(according to ISO10240)
- g) Load distribution
 - Please refer to the maximum numbers of passengers and load capacity of the boat in this manual or on the builder's plate. Do not exceed the maximum number.
 - Position the passengers and distribute the load evenly in the boat to help counterbalance the weight of the outboard.
 - In rough waters, load can be moved forward to ease the motion of the craft.
- h) If some of those onboard are children, the total number of people allowed onboard may be increased, provided that:
 - The total weight of the children does not exceed 37.5Kg; and that
 - The total weight of all allowed onboard (based on about 75Kg per adult) is not exceeded.

Warning

Do not exceed the maximum recommended number of persons. Regardless of the number of persons on board, the total weight of persons and equipment must never exceed the maximum recommended load. Always use the seats/ seating spaces provided.

When loading the boat, never exceed the recommended maximum load. Always load the boat carefully and distribute loads appropriately to maintain design trim (approximately level). Avoid placing heavy weights high up.

Do not install an engine in this boat with a higher rated power than that indicated on the Builder's plate as below.

Do not operate the boat with an engine of rated power greater than the maximum recommended power. Overpowering a boat can result in serious injury, death or boat damage.

Use negative trim to go from cruising speed to planning speed and at low speeds (applicable to boats equipped with a system for directing the propeller thrust).

Do no drive the boat at high speed with a negative trim of the propulsion equipment (bow down).

Recommended Seating Arrangement

NOTE: ● Occupant Position

(All boats only come with 1 molded seat as standard.)

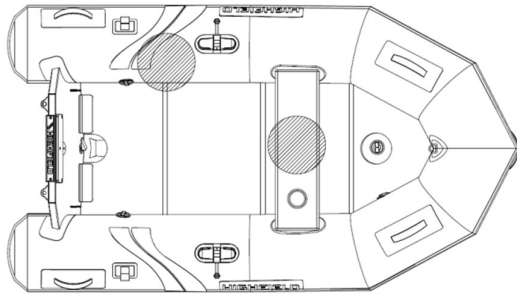

200KAM/AL

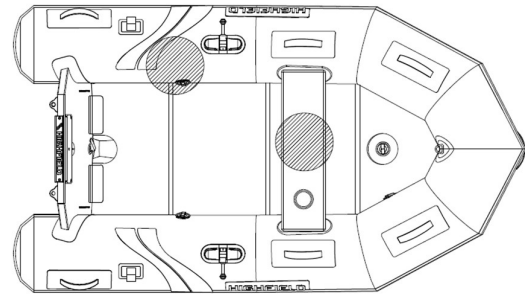

230KAM/AL

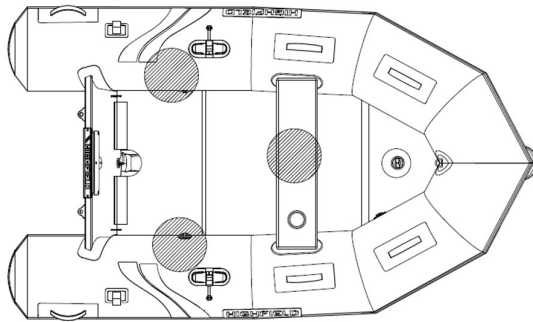

250KAM/AL

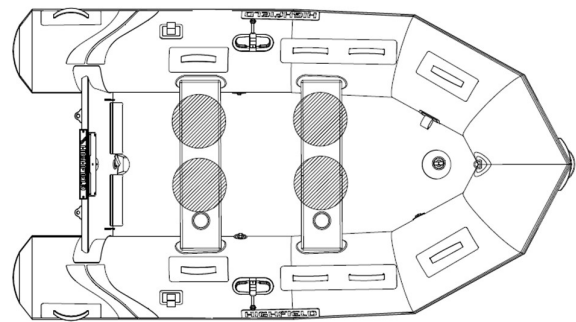

280KAM/AL

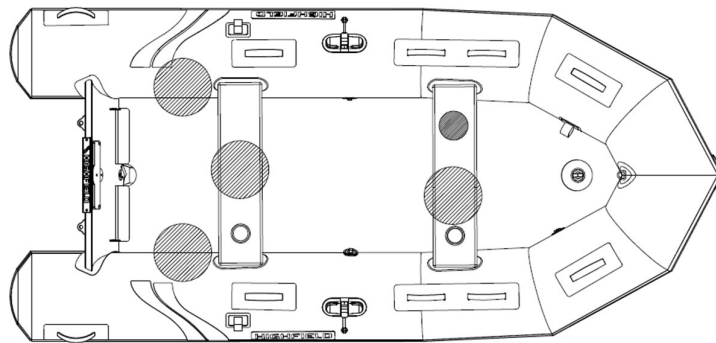

320KAM/AL



Builder's Plate:





Part of the information is given on the builder's plate affixed on the inside of the boat transom. A full explanation of this information is given in the relevant sections of this manual.

HIGHFIELD
aluminium boats

Model ^b Cat. ^c

 ≤ ^d kW HP
 kg lbs

 +  ≤ ^e +

 +  +  +  ≤ ^f kg lbs

 = ^g bar psi

BUILT TO ISO 6185-__ Type__
Highfield Boats Co., Ltd.
Baojia Industrial Zone, Poyu Town, Weihai, China
www.highfieldboats.com 

- a- Name of manufacturer
- b- Model
- c- Design category
- d- Maximum motor power
- e- Maximum number of persons
- f- Maximum load capacity
- g- Recommended working pressure

Boat Components



Front view



Stern view



Transom view



Bow view

Floorboard Installation

Instructions to install the floorboards in the Roll-up models:

1. Bottom floor

When you purchase a new Rollup from Highfield, the floor boards are already installed in the boat bottom. To prepare your boat you only need to inflate your tube as described in the operation section of this manual. If you need to remove the floor and reinstall it by yourself, please follow the instructions below:

- Make sure the boat is deflated when you want to take out or install the floor boards.
- Take the board "Part 1" and push it through the belt in the middle.
- Insert the board and make sure it's in the same position as Part 1 shown in the drawing below.
- Inflate the tube.
- Close the valves.

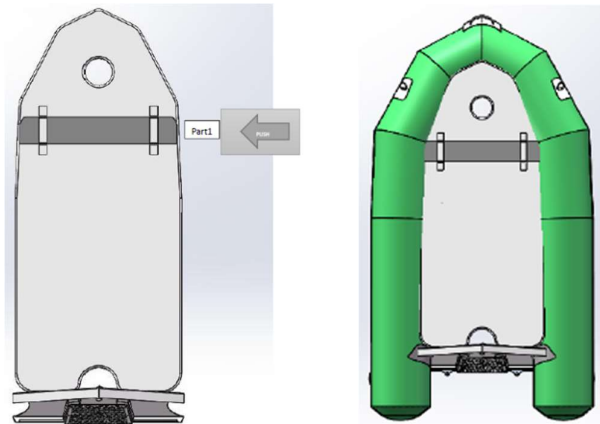

2. Air mat floor

This is a flat inflatable floor with a separate inflatable keel and a thrust board. Please refer to the instruction below to install the air mat floor.

- The keel B is already stuck to the bottom when the boat is packed by Highfield. DO NOT move the keel.
- Install the thrust board A through the belt on the downside of the air floor. The thrust board must be placed under the air floor and on top of the keel B.
- Place the deflated air floor in the boat. (DO NOT inflate the keel.) Make sure the hole cut in the deck is exactly on top of the valve of the keel.
- Inflate the inflatable floor to approximately 0.3bar/4.35psi.
- Push the sides of the floor under the tubes as far as possible.
- Inflate the air floor to minimum 0.6bar/8.70psi, maximum 0.8bar/11.60psi.
- Inflate the keel to maximum 0.25bar/3.63psi.
- Inflate the tube. (Please refer to the Inflation instructions of this manual.)

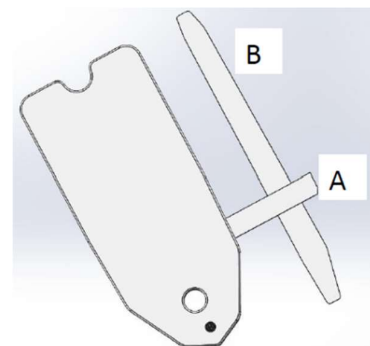
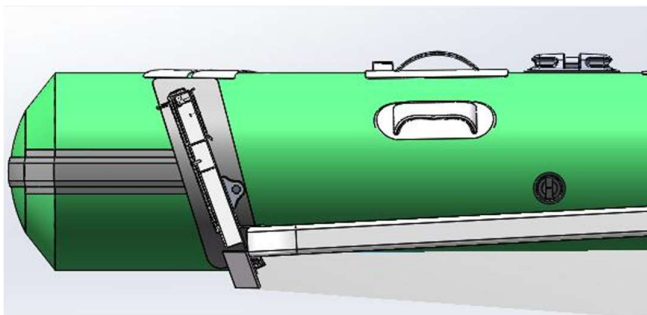

3. Aluminum floor

- Place Part 1 as far in the front of the boat as possible. Make sure the hole in the deck is aligned with the valve of the keel.
- Place Part 2 into the boat. Put the two parts of floorboard in line.
- Take Part 3, eventually Part 4, and make a bridge with Part 2/ Part 3.
- Push these parts down to the bottom of the boat.
- Install the aluminum stringers in the side of the floor.
- Follow the inflation instructions and inflate the tube to maximum 0.25bar/3.63psi.
- Inflate the keel, and then the floor will be in a level position.

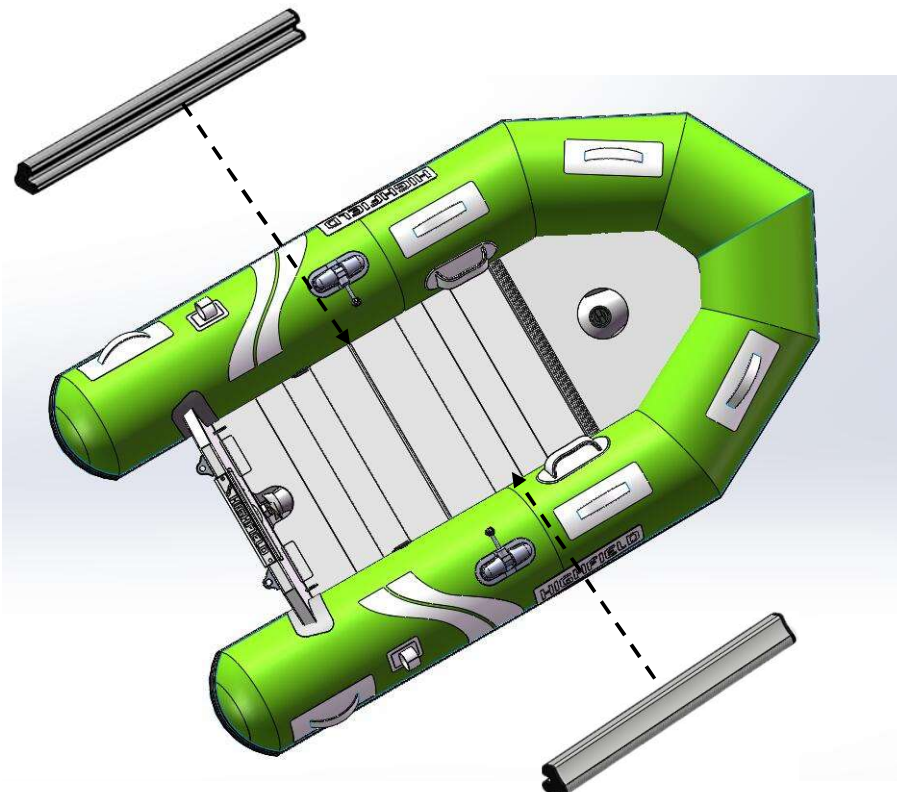
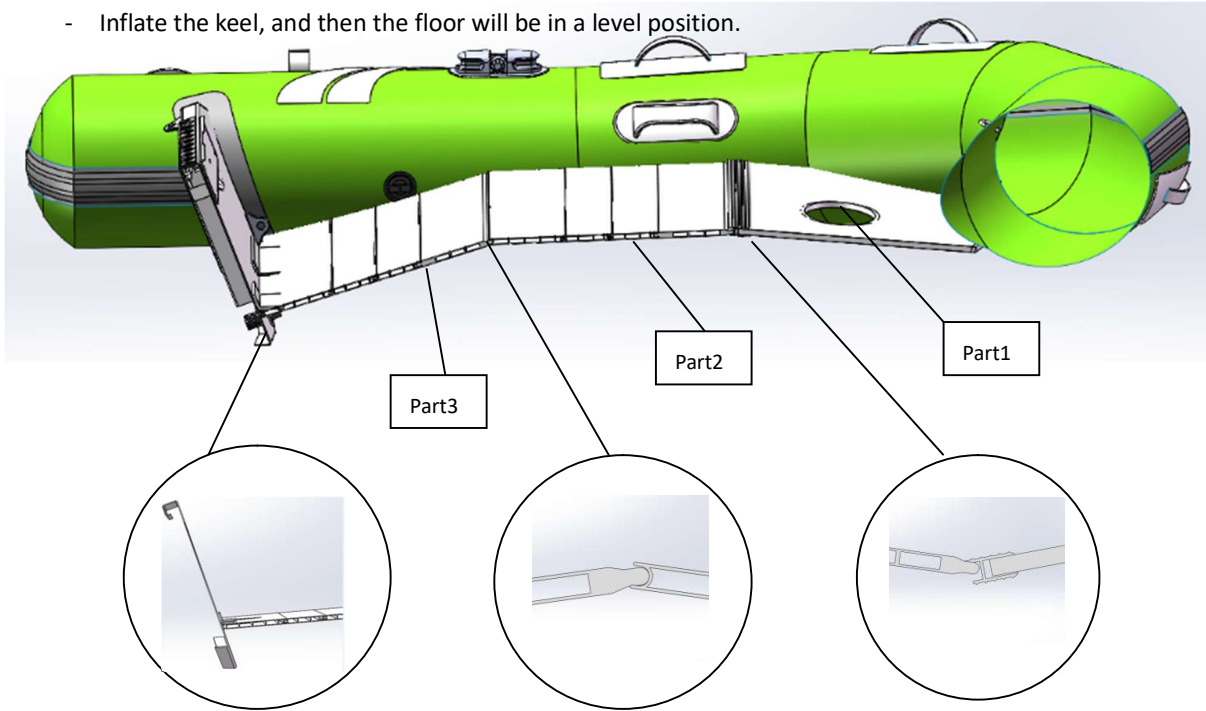

Install the aluminum stringers on both sides

Information Connected With the Risk of Flooding and Stability

1. Use of drain plug

Your boat is equipped with the following types of drains plug. When driving the boat, open the plug to drain the water on the floor. The water will automatically be drained by venture effect. When launching the boat or stopping on the water we recommend you to keep the plug sealed. When the boat is lifted, stowed, stored, not used, or transported, drain plug shall remain open to drain any water that could fill the deck.

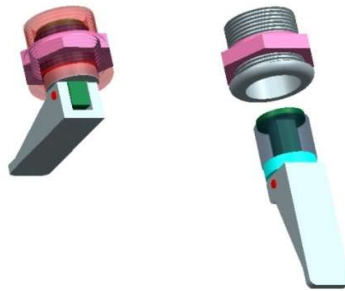

Caution

Keep the bilge drain plug open when the boat is kept outside of the water. The rain water could fill the boat and create stress and damage.

Danger

Do not open the bilge drain plug when the boat is afloat.

Do not try to access the bilge drain plug when motor is running. Propeller may cause serious injury.

2. Stability and buoyancy

This boat has been assessed as capable of supported the weight of the crew, even in the event of flooding.

- a) Fully laden displacement was used to evaluate the stability and buoyancy of the boat. The value of this displacement can be found in paragraph "Specifications" as below.
- b) Any changes in the distribution of loads onboard (for example by adding a raised structure for fishing, fitting radar or in-mast furling, changing the engine etc.) can significantly affect the boat's stability, trim and its performance.
- c) It is important to keep water in the bilges to a minimum.
- d) The boat's stability is affected by adding to the weight of the superstructure.
- e) When under way, it is advisable to shut the hatches, lockers and doors to minimize the risk of flooding.
- f) The boat's stability can be reduced when towing a boat or when using a davit or boom to lift a heavy load.
- g) Air chambers shall not be punctured.
- h) Breaking waves are a serious stability hazard.

Warning

Always adjust the speed and heading of your boat according to the sea conditions.

All of the watertight hatches and bilge drain plug must remain closed when at sea.

Transporting

1. For optimum handling, the trailer must be properly loaded and balanced.
2. Keep the center of gravity low for best handling.
3. Approximately 60 percent of the boat's weight should be positioned on the front half of the trailer and 40 percent in the rear.
4. The boat should also be balance from side to side. If the vessel has side mounted fuel or water tanks and only one side is filled, then this will lend the rig to maneuver poorly. Proper balancing will also prolong the life of your trailers tires.
5. The boat should be firmly secured with at least two ratchet type straps, one attached from the trailer to the stern eyes and one strap from the trailer, to the bow eye to keep the boat from shifting forward. The bow eye should also be attached to the trailer's winch which is mounted forward of the bow. Make sure you have sufficient clearance to avoid to damage outboard or boat during transportation.
6. Roll-up models can be accommodated/ transported on a roof rack. We recommend the boat to be protected from the roof rack that could damage the tube material. Boat should be stowed upside-down. Oars, bench seat and equipments should be removed from the boat. Boat must be secured using reliable nylon tie-down straps with cam-buckles. We recommend also tying a small rope off at the bow towing eye for extra safety.

Engine Start

Before starting the engine, it is imperative:

- a) To open the fuel supply valve
- b) To switch on the battery supply by using the battery isolator switches
- c) To put the control lever in neutral
- d) To attach the circuit-breaker/ kill switch lanyard to the pilot.

Make sure a habit of looking to see if sea water is pumped out with the exhaust gases as soon as you start the engine. If no water runs out, stop the engine immediately. Check the coolant flow.

Danger
<i>Before using the engine, make sure you carefully read the handbook provided by the engine manufacturer.</i>
<i>Always start the engine with the control lever in neutral.</i>
<i>Learn how to judge the necessary distance of deceleration for the vessel to come to a complete stop (The reverse gear is not a brake)</i>
<i>Use the kill switch lanyard.</i>

Operation

1. Inflation

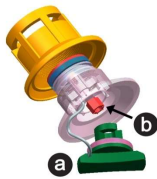

- a- Valve cap
- b- Plunger

- (1) To inflate the chamber, first unscrew the valve cap by turning a quarter of a turn counterclockwise. Check that the plunger in the center of the valve is closed i.e. upper position. If closed i.e. spring compressed, down position, push the plunger down and rotate to the closed position.
- (2) Connect the air pump to the valve, rotate the connector into the valve to lock it and start inflating. No matter you used foot pump or electrical, please do not inflate over the maximum air pressure 0.25bar/3.63psi per chamber.



- (3) How to use a two-stage pump on the high-pressure floor of KAM models?

Hose should go on the center connection of the pump marked "out" and the hi volume plug should be inserted when filling the main 3 chambers and the keel, the pump in this position will only produce about 3 PSI. The volume relief plug should then be removed when inflating the high-pressure floor to 10-13 psi. With the volume relief plug removed the pump can achieve 10-15 PSI.



- (4) Use air gauge to measure the tube pressure. We recommend the use of Bravo R151090 as following.

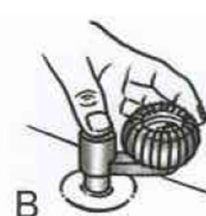
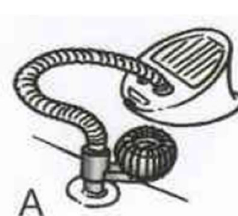

- (5) Be sure to inflate each chamber in turn according to the sequence shown below. Do not inflate a chamber completely then move on to the next one. Start with the rear chambers. Repeat procedure until all chambers are evenly inflated to the recommended working pressure.

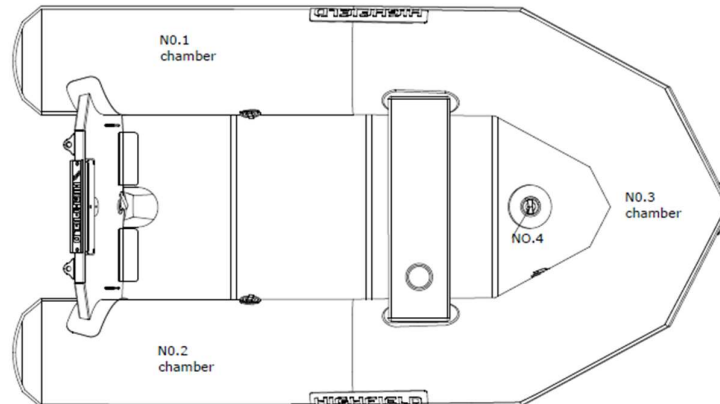

- (6) When inflating, please keep the air pressure balance between air chambers to avoid the damage of bulkheads.
- (7) Inflatable boats can be damaged by extreme internal air pressure. Such pressure can be caused by temperature differences. A boat properly inflated in the morning may become dangerously over-pressurized as the day warms up. The internal pressure can multiply many times as the surfaces temperature increases and under such conditions, seams can separate and bonded materials can delaminate. Avoid subjecting your inflatable to such conditions by relieving pressure in all chambers of your boat as the day heats up or before leaving the boat exposed to hot midday sun. It is highly recommended that the boat be stored in the shade or under cover when it is not being used.
- (8) Using the boat with under inflated tubes may cause serious damage, including transom cracking.

Caution

Do not use a compressed air source to inflate the tube or you may compromise the integrity of the seam or internal baffles. Seams or baffle rupture due to non-respect of inflation procedure is not covered under the warranty.

2. Performance

- (1) To achieve best performance, the boat must plane. If the boat does not plane you may check the following:
- Make sure the bilge/ deck is dry, drain the water otherwise.
 - Make sure the tube is correctly inflated.
 - Make sure you have the correct weight distribution. Sea conditions may require passengers to move forward to the boat to get the boat on plane before they return to their initial positions.
- (2) The outboard engine plays a big role in the performance of the boat. Please make sure you use a suitable outboard engine for the boat.
- (3) Outboard trim angle can be adjusted to improve planning and general performance. Adjust the position of the trim rod of your motor to define the trim angle of the outboard motor in relation to the transom. Make test runs with the trim set to different angles to find the position that works best for your boat and operating conditions.



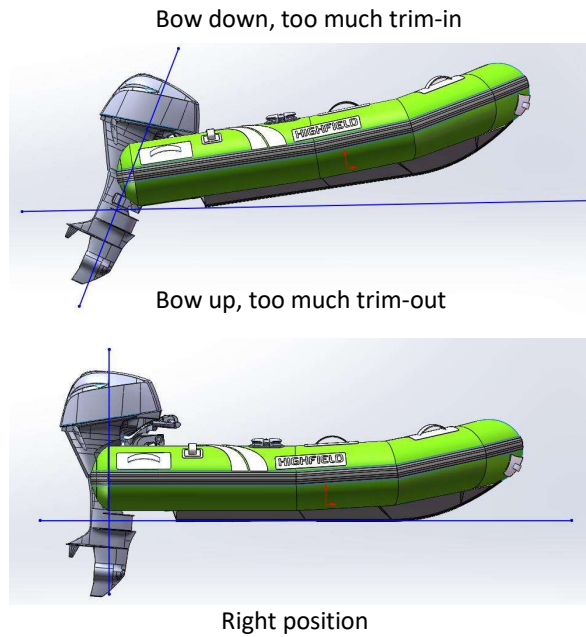

3. Towing

Your boat can be towed using the D-ring located at the bow. Make sure to use a tow line that is rated at least 5 times the weight of the boat being towed. The boat should only be towed using the D-ring. Molded handles, lifelines and cleats are not designed to be used for towing.

- a) It is recommended that the boat be towed with a bridle arrangement using the D rings on the either side of the bow.
- b) Please note that towed dinghies need to be constantly monitored and especially at night.
- c) When a dinghy is towed, the conditions may vary quite dramatically so the responsibility for its security rests entirely with the skipper.

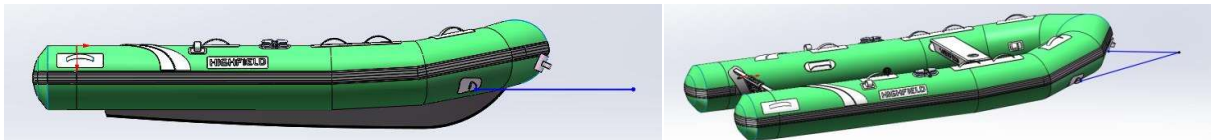

Warning
<i>The boat must be empty when towed.</i>
<i>Remove outboard motor, fuel tank and equipment before towing.</i>
<i>No passengers should be onboard.</i>
<i>The boat should be towed at low speed.</i>

4. Lifting

When using a hoist to lift the boat, attach the hoist to the 3(or 4 according to your boat's type) lifting eyes welded to the hull. Empty the boat of all equipment and make sure no passenger is onboard during lift. Make sure the deck and bilge are drained before lifting your boat. Remove the drain plug during the whole time the boat is stowed to allow water to run off. Molded handles, lifelines and cleats are not designed to be used for lifting. When lifting and slewing, ensure people are well clear below the slung vessel.



5. Beaching

We recommend the boat not to be powered on to the beach, dragged across rocks, sand, gravel or pavement as damage to the fabric and/or hull result.

6. Outboard motor

Install the outboard motor on the transom so that it is positioned as close to the center as possible. Tighten the transom clamp screws evenly and securely. Occasionally check the clamp screws for tightness during operation of the outboard motor because they could become loose due to engine vibration. Make sure the outboard motor is securely fastened to the transom every time before operation. It is wise to tie the engine to the transom as well as clamping eyes are provided. Always use the kill switch lanyard properly.

The portable tank should be removed from boat when fuelling. The tank should be filled in a ventilated area.

Do not smoke onboard.

Warning

Overpowering a boat can result in serious injury, death or boat damage. Do not use outboard that exceeds the maximum horsepower given on the motor plate.

Man-overboard Prevention and Recovery

1. Man-overboard prevention

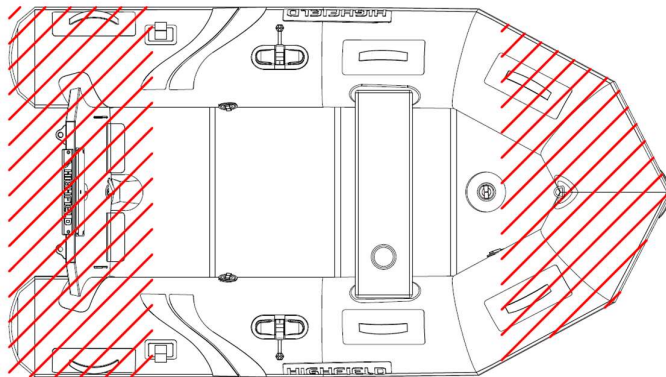

- a) The zones outside the working deck area are the red hatched area as above.
- b) The “working deck” means those areas where people stand or walk during normal use of the boat.
- c) Standing on the bow locker or sundeck is prohibited.

2. Recovery-getting back onboard

The means for getting back onboard must be able to be deployed by one person alone in the water, with no other help. We recommend the use of a rope ladder (not supplied with the boat). Illustrations of rope ladders for information purpose only:

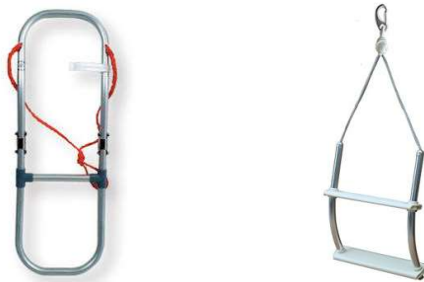

Danger

Make sure the means for getting back onboard are readily accessible and easy to use by someone alone in the water

3. Danger from moving parts

Keep the engine off whenever the engine box/cover/hatch is open. The engine box/cover/hatch serves as a machinery guard. Clothing or body parts can get caught in moving parts, causing death or serious injury. Keep away from moving part.



Danger

Contact with a spinning propeller can cause injury and death.

Do not enter or exit the water when the engine is running (ON) and the propeller is spinning.

Do not get on the swim platform when the engine is running.

Do not swim towards the back of the boat if the engine is on.

Maintenance

1. General care

Your inflatable has been especially designed to avoid maintenance problems as far as possible. However, periodic cleaning will help to keep your boat's good condition especially before winter storage. Clean your boat and wash it thoroughly with soapy water. Rinse carefully and check that no dirt or foreign bodies such as shell, sand or fishing hooks are left inside that might deteriorate the fabric. For tar stains use a gentle, nonabrasive cleanser such as dishwashing soap, or use a recommended inflatable boat cleaner available from most boat chandlery outlets.

For upholstery, Highfield is using marine grade fabric to offer best resistance to UV and ageing. Periodic washing with mild detergent and warm water is the best way to keep your upholstery look good. Special vinyl cleaner can also be used to remove difficult stains.

No fabric can last forever when constantly exposed to the sun. To make sure your PVC tubes last, a UV protectant solution must be applied twice a year on the tube fabric. We recommend the use of 303® Aerospace Protectant™.

Caution
<i>Do not use abrasive or aggressive chemical compounds.</i>
<i>Warm soap water is best in most situations.</i>
<i>Do not use any solvents, petrol, etc. (PVC models).</i>
<i>Use solvents sparingly only on Hypalon models.</i>
<i>Test any cleaner on a piece of patch material if in doubt.</i>

2. Deflation

To deflate the chamber, first unscrew the valve cap by turning a quarter of a turn counterclockwise. Check that the plunger in the center of the valve is closed i.e. upper position. If closed i.e. spring compressed, down position, push the plunger down and rotate to the closed position.

Connect the air pump to the valve, rotate the connector into the valve to lock it and start deflating.

Deflate each chamber in turn, do not deflate a chamber completely then move on to the next one. Start with the rear chambers. Repeat procedure until all chambers are completely deflated.

Caution
<i>This is not an exhaustive list of recommendations: Your dealer will give you the advice you need and will carry out the technical maintenance of your boat.</i>

3. Storage

We recommend you to cover your boat when not in use.

- a) When not in use boat should be removed from water.
- b) Before storage the boat should be cleaned and rinsed with fresh water.
- c) Do not cover boat before it is completely dry or mildew could grow under the cover and damage the tube material
- d) The covers should be ventilated and the drain plug left out.
- e) Check the expiry dates of the safety equipment.
- f) Have the boat overhauled.
- g) Grease and close all the valves and through-hull fittings.
- h) Grease all mechanical and moving parts (bolts, hinges, locks...).
- i) Close all the boat's seacocks.

-
- j) Put the covers back on the electronic screens.
 - k) Air all of the cushions and upholstery for a good while before putting them back onboard and arranging them so as to limit the surface areas touching.
 - l) Remove the movable upholstery.
 - m) Disconnect the batteries. Make sure you recharge them during the winter period if the boat is left inactive for too long.

Caution

The winterization of the engine requires the skills of a professional engineer: please consult your dealer.

This is not an exhaustive list of recommendations: Your dealer will give you the advice you need and will carry out the technical maintenance of your boat.

4. Tube repair

(1) Repair Kit contains:

- a) Fabric patches;
- b) Ready to use tube of special glue

(2) Conditions necessary for a successful repair:

- a) Humidity max 60%.
- b) Temperature range between 18 and 25 degrees Celsius.
- c) Repairs should not be carried out in direct sunlight, wind or rain.
- d) Repairs should, however, be undertaken in a well-ventilated area.

(3) Repair PVC boats:

Highfield Inflatables that have tubes constructed with Valmex PVC coated fabrics require PU based adhesive and RC hardener. Acetone solvent is recommended to prepare the surface before gluing. Use only recommended solvent and adhesive.

- a) Identify the area to be patched. This can be done by running water over the suspect area or spraying or brushing with soapy water.
- b) If the hole is only small, cut out a round patch of no less than 60mm diameter. Large holes or cuts will require proportionately larger patches but always ensure you have at least 30mm of patch around the perimeter of the cut or hole and the corners are well radiused
- c) Next hold the patch on the tube and mark out around it with a pencil.
- d) Clean both surfaces with solvent and spread a thin layer of adhesive over them ensuring there are no lumps.
- e) When the first coat is dry to the touch (about 10 to 15 minutes) apply a second thin coat.
- f) After waiting 5 or 6 minutes, touch the adhesive with the back of your hand. If it no longer appears wet, heat both areas with a hot air gun to re-activate the glue and join the patch to the tube and then clamp or roll the surfaces together. For the best adhesion, roll over the patch with a roller or over the bottom edge of a bottle.

Caution

Do not inflate the boat fully for 24 hours.

(4) Repair Hypalon boats:

Highfield Inflatables that have tubes constructed with Orca Hypalon coated fabrics cannot be bonded with plastic adhesives or by welding. They require neoprene based glue and RFE hardener. MEK solvent is recommended to prepare the surface before gluing. Use only recommended solvent and adhesive.

- a) Identify the area to be patched. This can be done by running water over the suspect area or spraying or brushing with soapy water.
- b) If the hole is only small, cut out a round patch of no less than 60mm diameter. Larger holes or cuts will require proportionately larger patches but always ensure you have at least 30mm of patch around the

-
- perimeter of the cut or hole and the corners are well radiused.
- c) Next hold the patch on the tube and mark out around it with a pencil.
 - d) Use a grinder, course sand paper or scratch stone, rough up both the back of the patch and the area marked on the tube.
 - e) Clean both surfaces with solvent and spread a thin layer of adhesive over them ensuring there are no lumps.
 - f) When the first coat is dry to the touch (about 10 to 15 minutes) apply a second thin coat. After waiting 5 or 6 minutes, touch the adhesive with the back of your hand. If it no longer appears wet, heat both areas with a hot air gun to re-active the glue and join the patch to the tube and then clamp or roll the surfaces together. For the best adhesion, roll over the patch with a roller or over the bottom edge of a bottle.

Caution

Do not inflate the boat fully for 24 hours.

Danger

Glue and solvent used for repair are highly flammable. Perform repairs in a well-ventilated area. Avoid breathing the vapors, wear protective gears (goggles, filter respirators, latex gloves).

Warranty

The product you have purchased comes with a limited warranty from Highfield Inflatables. The terms of the warranty are set forth in the Warranty Information section of this manual. The warranty statement contains a description of what is covered, what is not covered and the duration of coverage. Please review this important information. The description and specifications contained herein were in effect at the time this manual was approved for printing. Highfield Inflatables, whose policy is one of continued improvement, reserve the right to discontinue models at any time, to change specification, designs, methods, or procedures without notice and without incurring obligation.

Record your Hull Identification Number (HIN).

The HIN is located on the transom plate of your boat. You will need this information to obtain parts, warranty service or provide information if your inflatable boat is stolen.

HIGHFIELD BOATS - RETAIL LIMITED WARRANTY

1. WHAT IS COVERED

Highfield boats are warranted to be free of defects in material and workmanship during the period described hereafter:

2. DURATION OF COVERAGE

The entire vessel is covered for a period of **two (2) years** from the date the product is sold.

The hull structure is covered by a **five (5) years** warranty.

For commercial use or hire, the entire vessel has a **one (1) year** warranty.

3. CONDITIONS THAT MUST BE MET IN ORDER TO OBTAIN WARRANTY COVERAGE

Warranty coverage is available only to customers that purchase from an authorized Highfield dealer. Routine maintenance outlined in the Owner's manual must be performed in a timely manner in order to maintain warranty coverage. If the retail customer performs this maintenance, Highfield Boats reserves the right to make future warranty coverage contingent on proof of proper maintenance.

4. POWDER COATING

The powder coating is warranted for a period of two (2) years against manufacturing defects.

This warranty excludes damage due to misuse of the boat and chemical or mechanical shocks such as:

- collision, fire, theft, riot, etc.
- alteration, modification, tampering
- environmental corrosion and shocks due to acid rain, chemical fallout, industrial pollution, bird lime, tree sap, hail, extreme weather, etc.

5. WHAT HIGHFIELD BOATS WILL DO

Highfield Boats sole exclusive obligation under this warranty is limited to, at our option, repairing a defective part, replacing such part or refunding the purchase price of the Highfield Boats product. The repair, replacement of parts, or the performance of service under this warranty does not extend the life of this warranty beyond its original expiration date.

6. HOW TO OBTAIN WARRANTY COVERAGE

The customer must provide Highfield Boats with a reasonable opportunity to repair, and reasonable access to the product for warranty service. Warranty claims shall be made by delivering the product for inspection to a Highfield Boats dealer authorized to service the product. If the service provided is not covered by this warranty, the purchaser shall pay for all related labor and material, and any other expenses associated with that service. The purchaser shall not, unless requested by Highfield Boats, ship the product or parts of the product directly to Highfield Boats. Proof of registered ownership must be presented to the dealer at the time warranty service is requested in order to obtain coverage.

7. WARRANTY EXTENSION

Warranty extension becomes available upon proper registration of the product by the owner via Highfield Boats warranty website: <http://warranty.highfieldboats.com>. Product must be registered within sixty (60) days from the date the product is purchased.

Warranty extension covers the ability of the tube fabric to hold air to ISO 6185 (airtightness test).

Duration of the coverage:

Tube made of ORCA® (Hypalon) fabric: ten (10) years from vessel date of purchase.

Tube made of Valmex® (PVC) fabric: five (5) years from vessel date of purchase.

The standard two (2) year seam coverage will also be extended to a total of ten (10) years ORCA® (Hypalon) and five (5) years Valmex® (PVC) after warranty extension.

Warranty extension does not apply if the vessel is used for rental or commercial use.

8. WHAT IS NOT COVERED

- a) This limited warranty does not include damage due to misuse abuse, negligence, improper or inadequate storage or transportation, or to any Highfield boat which is used in a manner contrary to directions or instructions indicated in the Highfield Owner's Manual.
- b) The warranty does not cover routine maintenance items, adjustments, normal wear and tear, puncture, discoloration, oxidation, abrasion, mildew or damages due to theft, loss, modification or alternation.
- c) Wear parts including but not limited to rubbing strake, keel guards, ropes are not covered by the warranty.
- d) This warranty shall be ineffective if the boat has been operated without proper inflation, or with an outboard motor which exceeds the maximum horsepower rating listed on the serial plate attached to the transom.
- e) Powder coating condition is not covered by our warranty due to the specific exposed nature of the product, for best long term protection, ensure that your surfaces are rinsed with fresh water after every use and are cleaned immediately of any substances that may stick to the paint surface and cause discoloration or damage. We recommend scratches and dents to be repaired as soon as possible after they occur.
- f) Use of the product for racing or other competitive activity voids the retail warranty.
- g) Expenses related to haul-out, launch, towing, storage, transportation, telephone, rental, inconvenience, slip fees, insurance coverage, loan payments, loss of time, loss of income, or any other type of incidental or consequential damages are not covered by this warranty.

9. TRANSFER OF WARRANTY

The limited warranty is transferable to a subsequent purchaser, but only for the remainder of the unused portion of the limited warranty. This does not apply if the vessel is used for rental or commercial use.

To transfer warranty please send an email with the below information to warranty@highfieldboats.com.

- a) Copy of the sale agreement.
- b) HIN of the boat
- c) Name, address, and email address of new owner.

Product Information	
<i>Model</i>	
<i>HIN</i>	
<i>Purchase Date</i>	
Dealer's Information	
<i>Name</i>	
<i>Address</i>	
<i>Phone</i>	
<i>Dealer's Stamp</i>	
Customer's Information	
<i>Name</i>	
<i>Address</i>	
<i>Email Address</i>	
<i>Phone</i>	

Service assistance

For assistance please contact your Highfield dealer and visit Highfield Inflatable website:

www.highfieldboats.com